



Touch-free Faucets

**For Patient Care
Applications**

**CHICAGO
FAUCETS** 

Geberit Group

CHICAGO
FAUCETS

The battle against bacteria within healthcare facilities.

Avoiding healthcare-associated infections (HAIs) is mission critical.

From reinforcing hand-hygiene compliance to utilizing an arsenal of water treatment procedures, the campaign against the spread of bacteria is a primary concern among hospitals and long-term care centers across the country. Water is an essential ingredient in the effort. Ironically, water also contains small amounts of bacteria – making this battle even more challenging.

Hygiene, hand-washing, and electronic faucets.

The Centers for Disease Control and Prevention (CDC) ranks handwashing as the number one method to prevent the spread of bacteria. Even with total compliance, touching faucet handles can re-contaminate clean hands and contribute to the spread of infections. A recent study found that the microbial diversity on the handles of traditional manual faucets throughout a hospital can be significant. This finding reinforces the importance of reducing touch-points wherever possible, particularly in areas with severely immunocompromised patients.

Legionnaires' disease continues to be a challenge for healthcare facilities. The Centers for Medicare and Medicaid Services (CMS) expect Medicare and Medicaid certified healthcare facilities to have water management policies and procedures to reduce the risk of growth and spread of Legionella and other opportunistic pathogens in building water systems. This expectation returns the focus to studies of electronic faucets showing that they can elevate waterborne bacteria to a level higher than may be found in conventional manual faucets. While most individuals are not at risk for infection by these bacteria, any increase is reason for concern in health care environments. Many health institutions are looking for ways to reduce exposure among individuals who might have a higher risk of contracting Legionnaires' disease.

There is no need to prioritize between surface-borne and waterborne pathogens.

Special Pathogens Laboratory

Recovery of bacteria from sink faucet handles over a three-week period. Rooms tested include: ER, Pulmonary Kitchen, Pediatric Kitchen, Pediatric Patient Room, Oncology Restroom and Oncology Nourishment.

*Coagulase Negative Staphylococcus, Corynebacterium, Micrococcus, Moraxella spp., Delftia spp., and other skin and environmental bacteria also isolated in high quantities.

**Percentage = cfu of the subset of clinically relevant bacteria divided by the combined cfu's of same bacteria X 100

EXAMPLE OF MICROBIAL DIVERSITY OF POTENTIAL PATHOGENS RECOVERED FROM SINK FAUCET HANDLES (% TOTAL)

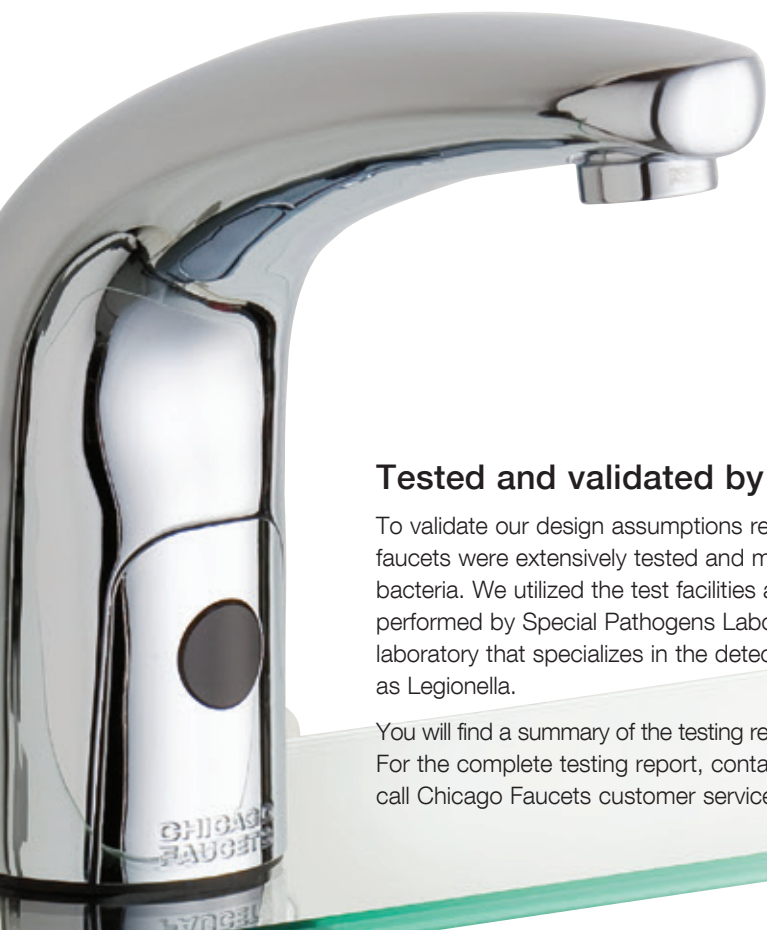
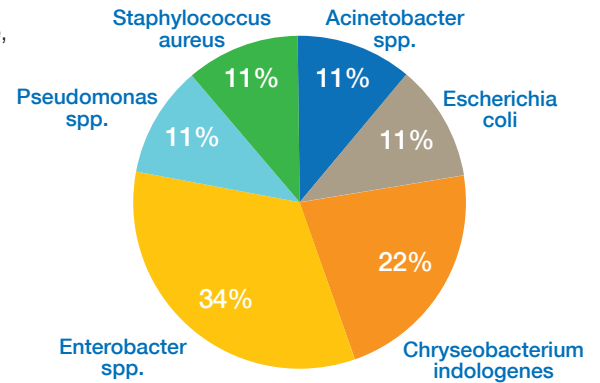

HyTronic® for Patient Care Applications

A proven solution for patient care applications.

HyTronic touch-free faucets for Patient Care Applications deliver a responsive, touch-free handwashing experience. An internal waterway is designed and constructed to limit the tested microbial contamination to a level statically similar to standards set by a conventional manual faucet. Options include a thermostatic mixing valve that provides point-of-use scald protection and tools that support plumbing system remediation protocols.

Tested and validated by a nationally-recognized testing laboratory.

To validate our design assumptions regarding the waterway design, HyTronic for Patient Care Applications faucets were extensively tested and monitored for both heterotrophic plate count (HPC) and Legionella bacteria. We utilized the test facilities at the University of Pittsburgh with culture and sample analysis performed by Special Pathogens Laboratory. SPL is a nationally-recognized analytical microbiology laboratory that specializes in the detection, control, and remediation of waterborne pathogens such as Legionella.

You will find a summary of the testing results in the back of this brochure. For the complete testing report, contact your sales representative or call Chicago Faucets customer service at 847-803-5000.



A complete system for high risk patient care areas.

We've designed a complete package specifically for patient care areas that helps reduce the spread of infection, provides protection against scalding, and prevents the cross-flow of dangerous bacteria from the hot supply into the cold supply and back into the plumbing system.



Patient Care-specific operating modes

Scrub, metering, and cleaning modes.



Remote control technology

Set, program, maintain and monitor your faucets with the Commander 116.585.00.1.



Low volume solenoid valve

Minimizes the amount of stagnant water.

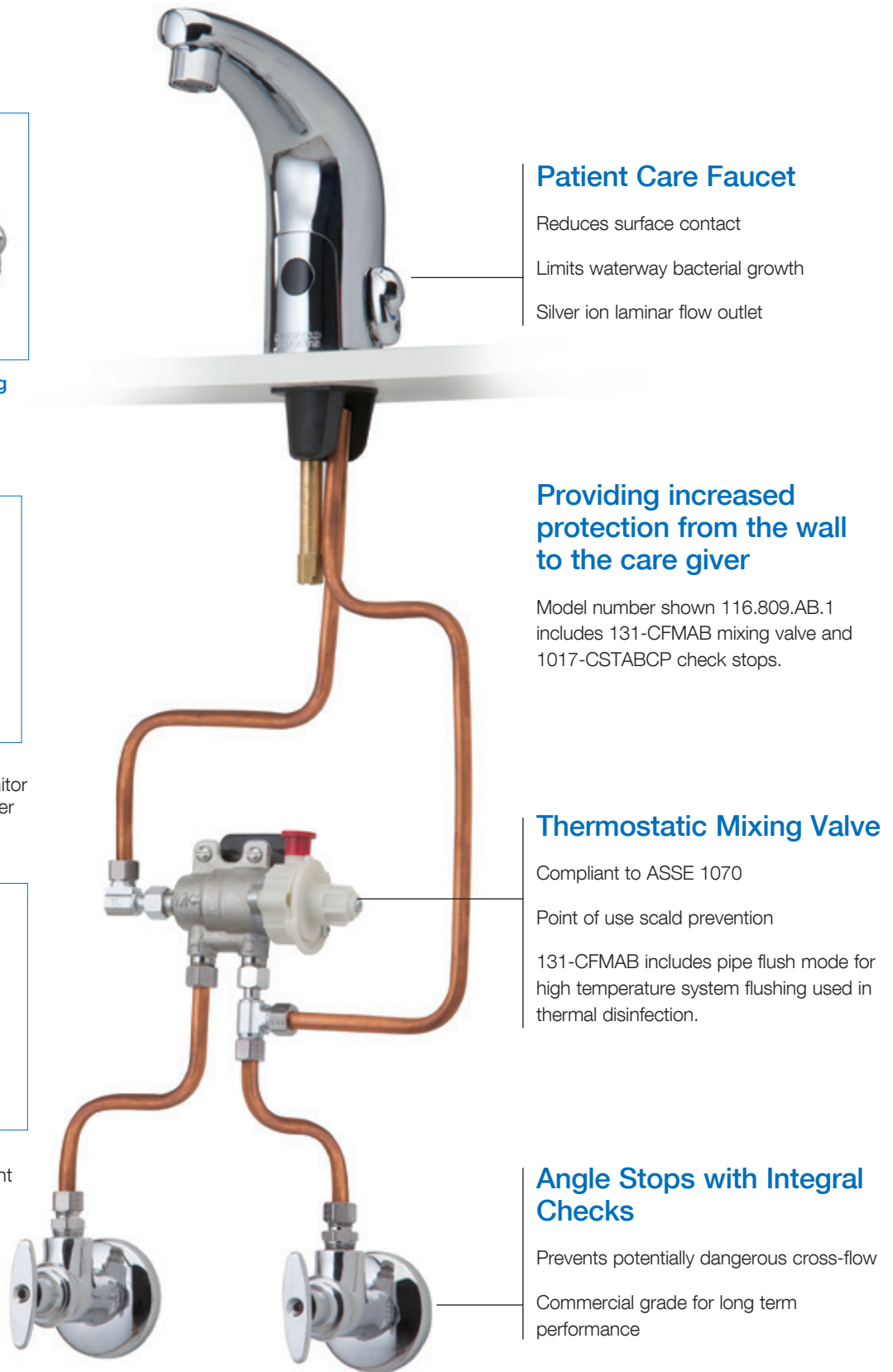

Patient Care Faucet

- Reduces surface contact
- Limits waterway bacterial growth
- Silver ion laminar flow outlet

Providing increased protection from the wall to the care giver

Model number shown 116.809.AB.1 includes 131-CFMAB mixing valve and 1017-CSTABCP check stops.

Thermostatic Mixing Valve

- Compliant to ASSE 1070
- Point of use scald prevention
- 131-CFMAB includes pipe flush mode for high temperature system flushing used in thermal disinfection.

Angle Stops with Integral Checks

- Prevents potentially dangerous cross-flow
- Commercial grade for long term performance

HyTronic® Faucets for Patient Care Applications

To see the full line of touch-free HyTronic for Patient Care Applications faucets visit our website at www.chicagofaucets.com.

Traditional styling and durable solid brass construction flow seamlessly into any interior design. Above-deck electronics provide a quick installation and years of superior, reliable operation.



- Antimicrobial laminar flow, low splash outlet.
- Copper tube inlets to reduce bacterial growth
- User-adjustable temperature control option

Gooseneck styling combines high clearance and deeper reach with the technological superiority of our HyTronic product line. Above-deck electronics provide a quick installation and years of superior, reliable operation.



- Antimicrobial laminar flow, low splash outlet
- Laminar flow, low splash, no outlet option
- Hygiene flush mode factory set
- Copper tube inlets to reduce bacterial growth
- User-adjustable temperature control option

LTPS

Long Term Power System

Allows you to install a touch-free faucet with a maintenance-free power option designed to last for more than 15 years at 500 uses per day.

EBPS

Emergency Backup Power System

AC with integrated backup power to deliver the necessary water during a power outage.

AC or DC

Hard-wire, Plug-in, or Battery

Install an AC-powered faucet for maintenance-free power or DC for easier installation.

Edge modern styling with all the commercial benefits of a cast brass spout. Above-deck electronics provide a quick installation and years of superior, reliable operation.



- Antimicrobial laminar flow, low splash outlet
- Hygiene flush mode factory set
- Copper tube inlets to reduce bacterial growth
- User-adjustable temperature control option

OSHPD Mixer specially designed to meet OSHPD criteria for a 4" wristblade mixer. Allows users to control the water temperature without the need to grasp the handle.



Model shown 116.829.AB.1

- OSHPD Compliant
- Easy-to-adjust hot water limit stop to help prevent scalding
- Available as single hole or with 4" or 8" cover plates

OSHPD Compliant

Compliant with California OSHPD and meets requirements for manual temperature controls.



Geberit Group

Research To Investigate Bacteria Growth in Electronic Faucets

Overview

Bacterial contamination of hot water systems is a common problem in large commercial facilities. Buildings such as hospitals, long-term health care centers, and hotels have large, complicated hot water distribution systems, and the growth of bacteria within these systems can cause both structural damage due to microbially-induced corrosion and human infection.

Legionella pneumophila are gram-negative bacteria which cause Legionnaires' disease, a potentially fatal form of pneumonia. Average, healthy individuals are not at high risk for infection by these bacteria, but individuals possessing a number of predisposing risk factors (elderly, immunocompromised, smoker, etc.) are at greater risk of contracting Legionnaires' disease should they be exposed to a contaminated source. Building hot water systems are sources of exposure to Legionella that have been linked to the cases of Legionnaires' disease in several instances [Colville et al. 1993, Goetz et al. 1998, Shands et al. 1985].

Heterotrophic plate count (HPC) measurements provide a generalized indicator of microbial water quality. They are used to determine water treatment process effectiveness (HPC before treatment vs. HPC after treatment), as well as to indicate if conditions which increase rates of microbial re-growth (i.e. high temperatures, lack of residual disinfectant, availability of nutrients, etc.) are present in a given environment. Although most HPC are not pathogenic, the relative presence/absence of microbial growth may be used as an indicator of the potential presence of pathogens (i.e., water with a large quantity of bacteria is more likely to have pathogens than water with very little bacteria).

Previous Research

In 2011, a study conducted by a leading healthcare institution indicated that sensor faucets are more susceptible to bacterial contamination and colonization than standard manual supply faucets.

Scope Of and Reason For Additional Research

The study was based on evidence gathered from faucets installed in a real life situation and the comparison was limited to only one specific electronic faucet product and one reference manual faucet. A second study, conducted by the University of Pittsburgh under guidance of Special Pathogens Laboratory and financed by Chicago Faucets, was performed to determine whether these field observations could be reproduced under well-controlled laboratory conditions.

Research Objectives

The key objectives of this laboratory study were:

- (a) to determine if electronic faucets are any different from standard mechanical faucets in promoting Legionella growth, and
- (b) determine if there is any difference between these two faucet types in terms of the efficacy of standard disinfection practice (free chlorine addition) for Legionella eradication.

Test setup and process

A model system was constructed to test nine electronic faucet varieties, which were compared with a "control" faucet (manual faucet). The electronic group contained a selection of standard catalog products, among them the product used in the Johns Hopkins study, and modified products to represent different combinations of features that may or may not contribute to microbial growth. Total HPC and Legionella bacteria were cultured from each set of faucets (each faucet type was represented by three faucets) and the data was analyzed for statistical significance of different factors in promoting biological colonization. An automated faucet flushing process controller was installed on the test sensor faucet system in order to simulate daily faucet usage within a typical commercial facility. All faucets were set to remain open for the duration of the investigation, and the passage of water through each faucet was controlled using solenoid valves. The opening and closing of these valves was programmed electronically to simulate realistic commercial water demand.

Legionella bacteria was prepared using a model cooling tower system supplied with municipal water. The tower was allowed to operate continuously for approximately one week, and subsequent testing indicated Legionella concentrations in excess of 10,000 CFU/mL. A measured volume of this solution was fed into the system to achieve an initial Legionella concentration of approximately 500 CFU/mL. The test was monitored for four weeks prior to a chlorination effort and two weeks post-chlorination. To disinfect the system, a volume of 45.4 mL of 6% bleach was added to the faucet system's holding tank, mixed, and circulated through the system for 2 hours and 20 minutes. Following disinfection, system flushing was re-enabled and system operation resumed.

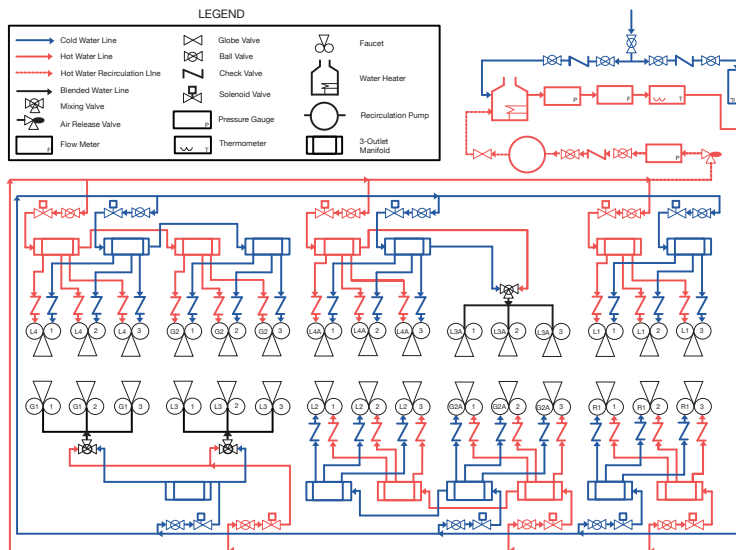

Results

In order to evaluate the significance of the observed differences between bacteria concentrations among different faucet groups, statistical analyses were performed using the collected data.

Legionella

It was found that each of the nine electronic faucets had an average concentration of Legionella bacteria that was comparable to the control faucet prior to chlorination. The mean difference of the faucet with the highest Legionella concentration prior to chlorination and the reference faucet was only 0.16 log CFU/mL.

Post-chlorination analyses also compared each sensor faucet to the control faucet, and the results indicate that five faucets demonstrated Legionella concentrations that were statistically equivalent to that of the control faucet. Two faucets, among them the one electronic faucet that was tested in the healthcare study, had Legionella concentrations that were more than 1.0 log higher than the control faucet.

HPC (Heterotrophic plate count)

Prior to chlorination, each of the electronic faucets harbored a population of total HPC which was equal to or greater than that of the control faucet. Five of the faucets were statistically indistinguishable from the control faucet. Four faucets demonstrated average pre-chlorination concentrations which were higher than those demonstrated by the reference faucet. The difference between the average concentration of the electronic faucet and the control faucet ranged from 0.03 log CFU/mL to 0.71 log CFU.

Post-chlorination comparisons of each of the sensor faucets with the control faucet indicate that one faucet maintained a population of HPC which was statistically equivalent to that of the control faucet. Two faucets demonstrated microbial counts greater than 1.0 log higher than the control, while all remaining faucets demonstrated microbial concentrations that ranged from 0.22-0.37 log above that of the control.

Summary

This study was performed in a well-controlled lab environment by the University of Pittsburgh under guidance of Special Pathogens Laboratory, The Legionella Experts, and financed by Chicago Faucets. The objective was to determine if electronic faucets are any different from standard mechanical faucets in promoting Legionella growth and if there is any difference between these two faucet types in terms of the efficacy of standard disinfection practice.

Statistical analysis of experimental results obtained during the pre-chlorination phase revealed that there is no significant difference in the ability of sensor faucets to promote Legionella colonization when compared to a standard mechanical faucet.

Sensor faucets did harbor higher concentrations of HPC compared to mechanical faucets. The findings demonstrated that some faucets fostered higher microbial concentrations during regular usage. Conversely, other faucet types demonstrated the lowest microbial concentrations among sensor faucets.

Disinfection of the faucet system was performed five weeks into the trial.

Statistical analysis revealed that five electronic faucets did not demonstrate a statistically significant difference in Legionella concentration from the control faucet after chlorination. These results were confirmed using disinfection log reduction of HPC bacteria from pre- to post-chlorination.

Following disinfection, three electronic faucets continued to foster the highest microbial concentrations (HPC), while five other faucets were not statistically different when compared to the levels observed in a standard mechanical faucet.

Overall, it can be said that selected and modified electronic faucets perform as well as the mechanical reference faucet when it comes to promoting Legionella colonization and HPC. Based on the results of this study, Chicago Faucets offers a selection of four modified electronic faucet products with both AC and DC power options. For more information on these products consult a Chicago Faucets representative.

Credentials: Special Pathogens Laboratory provides the healthcare and water treatment industries, hotels, and commercial and industrial sectors a comprehensive solution for the prevention and control of Legionella. Founded by Dr. Janet Stout and Dr. Victor Yu, internationally recognized experts in Legionnaires' disease.



Geberit Group



We are a member of the U.S. Green Building Council and support the Leadership in Energy and Environmental Design (LEED) Green Building Rating System™, to measure the efficiency and sustainability of buildings in the U.S. and Canada. If you are trying to achieve LEED Certification for your building, our low-flow outlets, metering cartridges, and sensor-operated faucets can contribute points in these areas: Water Efficiency Credit 2: Innovative Wastewater Technologies and Water Efficiency Credit 3: Water Use Reduction



We are proud to be a partner with WaterSense®, sponsored by the EPA and designed to protect the future of our nation's water supply by promoting efficiency and enhancing the market for water efficient products, programs, and practices.



We are a charter sponsor of the Alliance for Water Efficiency, a non-profit organization that is dedicated to the efficient and sustainable use of water. It brings together a diverse range of stakeholders to advocate water efficiency and conservation.



Geberit Group

Chicago Faucets, a member of the Geberit Group, is the leading brand of commercial faucets and fittings in the United States, offering a complete range of products for schools, laboratories, hospitals, office buildings, food service, airports, and sports facilities. Whatever your requirements may be, Chicago Faucets offers standard and made-to-order products that are designed to meet any commercial application.

The Chicago Faucet Company
2100 South Clearwater Drive
Des Plaines, IL 60018
Phone: 847/803-5000
Fax: 847/803-5454
Technical: 800/832-8783
www.chicagofaucets.com

